

# DRX3000

---

## Installation, Operation and Maintenance Manual

---



# DRX™ Impact Beds

---

Serial Number: \_\_\_\_\_

Purchase Date: \_\_\_\_\_

Purchased From: \_\_\_\_\_

Installation Date: \_\_\_\_\_

Serial number information can be found on the Serial Number Label included in the Information Packet shipped with the impact bed.

# Table of Contents

---

<b>Section 1 - Important Information</b> .....	<b>4</b>
1.1 General Introduction .....	4
1.2 User Benefits .....	4
1.3 Proper Impact Bed Selection .....	5
1.4 Selecting the Right Impact Bar .....	6
1.5 Installation and Service Option .....	6
1.6 DRX™ Impact Bed Spec Sheet .....	7
<b>Section 2 - Safety Considerations and Precautions</b> .....	<b>8</b>
2.1 Stationary Conveyors .....	8
2.2 Operating Conveyors .....	8
<b>Section 3 - Pre-Installation Checks and Options</b> .....	<b>9</b>
3.1 Checklist .....	9
3.2 Optional Installation Accessories .....	10
<b>Section 4 - Installation Instructions</b> .....	<b>11</b>
<b>Section 5 - Pre-Operation Checklist and Testing</b> .....	<b>15</b>
5.1 Pre-Op Checklist .....	15
5.2 Test Run the Conveyor .....	15
<b>Section 6 - Maintenance</b> .....	<b>16</b>
6.1 New Installation Inspection .....	16
6.2 Routine Visual Inspection .....	16
6.3 Routine Physical Inspection .....	16
6.4 Impact Bar Replacement Instructions .....	17
6.5 Maintenance Log .....	20
6.6 Impact Bed Maintenance Checklist .....	21
<b>Section 7 - Troubleshooting</b> .....	<b>22</b>
<b>Section 8 - Specs and CAD Drawings</b> .....	<b>23</b>
8.1 Specifications and Guidelines .....	23
8.2 CAD Drawings .....	24
<b>Section 9 - Optional Replacement Parts</b> .....	<b>25</b>
<b>Section 10 - Other Flexco® Conveyor Products</b> .....	<b>27</b>

# Section 1 - Important Information

---

## 1.1 General Introduction

We at Flexco are very pleased that you have selected a DRX™ Impact Bed for your conveyor system.

This manual will help you to understand the operation of this product and assist you in making it work up to its maximum efficiency over its lifetime of service.

It is essential for safe and efficient operation that the information and guidelines presented be properly understood and implemented. This manual will provide safety precautions, installation instructions, maintenance procedures and troubleshooting tips.

If, however, you have any questions or problems that are not covered, please visit our web site or contact our Customer Service Department:

**Customer Service: +27-11-608-4180**

**Visit [www.flexco.com](http://www.flexco.com) for other Flexco locations and products.**

Please read this manual thoroughly and pass it on to any others who will be directly responsible for installation, operation and maintenance of this cleaner. While we have tried to make the installation and service tasks as easy and simple as possible, **it does however require correct installation and regular inspections and adjustments to maintain top working condition.**

## 1.2 User Benefits

The “transfer point” is integrally important to the successful operation of a belt conveyor system. The material transferred from one conveyor (or other source) to another conveyor must be done without damaging the conveyor’s key component...the belt. A correctly-selected impact bed is critical for this task.

Since material size, weight and the drop height can cause considerable impact force that can damage the belt, the right impact bed must be chosen to absorb the impact energy and minimize any damage to the beltline.

The proper impact bed can also support the belt in the loading zone to prevent material spillage.

The DRX Impact Beds offer these features and benefits:

- Extra Belt Protection - DRX means “Dual Relief Xtra”. Our beds offer our exclusive Velocity Reduction Technology™, which means two levels of force reduction to absorb more impact energy and minimize transmission back to the belt. The impact bars are properly supported for one level of defense and unique Impact Energy Absorbers provide the second level of impact relief. The results: less belt damage and less rebounding and degradation of the materials.

# Section 1 - Important Information

---

- **Easy Maintenance** - Our Slide-Out Service™ is quick, safe and convenient. Each bed separates in the middle and the two sides slide apart. This provides easy access to all of the impact bars for replacement.
- **Cost Effective** - Each bed is constructed with steel channel crossbeams for long service life; and low-cost square washers and carriage bolts replace traditional, expensive T-bolts for securing the impact bars.

## 1.3 Proper Impact Bed Selection

DRX impact beds are expressly designed to absorb energy from falling materials. The bed model should be specified to the needs of the conveyor application. To do this, the following data points are needed (Also see the DRX Impact Bed Spec Sheet on Page 7).

1. **Belt Width** - This is typically a simple check and the only additional information that would be required is if belt width is inconsistent with structure width.
2. **Troughing Angle** - What is the angle of the current bed or troughing set?
3. **Roller Diameter and CEMA Rating** - Rollers are typically 125 mm or 150 mm and rated CEMA C, D or E.
4. **Bed Length** - Typically 1.2M or 1.5M. Special lengths available upon request.

Material	kg/m <sup>3</sup>
Coke	657
Fertilizer	961
Bauxite, crushed	1282
Potash	1282
Coal, Bituminous, Solid	1346
Coal, Anthracite, Solid	1506
Slag, Solid	2114
Chromium Ore	2163
Halite (Salt), Solid	2323
Phosphorus	2339
Stone (Common, Generic)	2515
Limestone, Solid	2611
Shale, Solid	2675
Granite, Solid	2691
Gypsum, Solid	2787
Trap Rock, Solid	2883
Dolomite, Solid	2899
Malachite (Copper Ore)	3860
Platinum Ore	4293
Hematite (Iron Ore)	5158

NOTE: Shale is approximately the same as limestone.

5. **Drop Height and Lump Size & Weight** - This is the critical information required.
  - a. **Drop Height** - The measurement from where the material leaves the feeding conveyor to where it makes contact with the receiving conveyor.
  - b. **Lump Size and Weight** - The lump size - The largest dimension of the material pieces dropping. The material weight is of the largest lump size found and weighed.
  - c. **Chart for Rough Calculations** - Weighing is always more accurate, but the chart values will give a rough weight estimate.

# Section 1 - Important Information

Now you can calculate the impact energy (in kg-m) and make the bed selection by the rating chart.

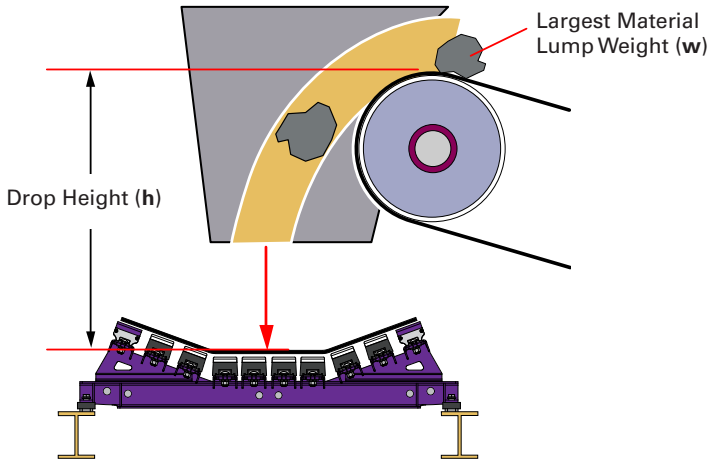

A sample DRX™ Impact Bed Spec Sheet is included (Page 7) for future use.

**By using this simple lb-ft formula, for whatever your application, you will know the load capacities needed to specify the best DRX™ Impact Bed to get the job done right.**

**Calculate Impact Energy:**

Lump weight \_\_\_\_\_ kg  
 x Drop length \_\_\_\_\_ m  
 -----  
 Total \_\_\_\_\_ kg-m

**Match lb-ft to bed rating:**

Up to 0-25 kg-m	DRX 200
25 to 100 kg-m	DRX 750
100 to 200 kg-m	DRX 1500
200 to 400 kg-m	DRX 3000

## 1.4 Selecting the Right Impact Bar

The primary purpose of the impact bars is to absorb the energy of the falling material and prevent damage to the belt. They are the first line of defense. Typical impact bars can be purchased with a 13mm UHMW top cover or with a longer-wearing 25mm top cover. Care should be taken to choose the right top cover thickness for your application to ensure maximum energy absorption.

Generally, impact bars are 75mm high and 100mm wide. They are made up of an aluminum extrusion base, an elastomer (rubber) center, and a low-friction (UHMW) top cover. The extrusion takes up about 25mm of the bar's height. That means that depending on the thickness of the top cover chosen 13mm or 25mm, the energy-absorbing rubber core is either 38mm or 25mm. Reducing the rubber core of each bar by 50% in heavier impact applications can reduce the impact bed's effectiveness and performance.

Some general guidelines:

1. The impact bed's primary use is for dust suppression with no sizeable amount of impact (for loads not exceeding 200 kg-m of impact energy), choose the 25mm top cover. It will offer twice the service life with no measurable performance degradation.
2. For applications with 200 kg-m or more of impact force, the 13mm top cover is strongly recommended. It will provide 50% more energy impact protection for the belt.

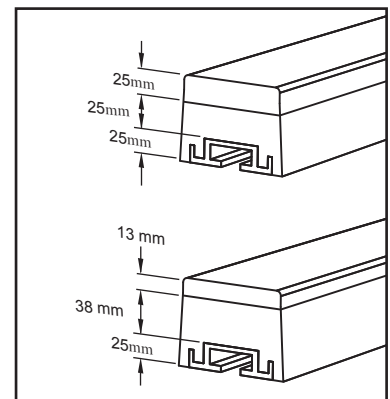

## 1.5 Installation and Service Option

The DRX™ Impact Bed is designed to be easily installed and serviced by your on-site personnel. However, if you would prefer complete turn-key factory service, please contact your local Flexco® Field Engineer or your Flexco Distributor.

# Section 1 - Important Information

## 1.6 DRX Impact Bed Spec Sheet

### CUSTOMER INFO:

Company Name: \_\_\_\_\_

Address: \_\_\_\_\_ Date: \_\_\_\_\_

\_\_\_\_\_ Phone #: \_\_\_\_\_

Contact Name: \_\_\_\_\_ Fax #: \_\_\_\_\_

Title/Position: \_\_\_\_\_ e-Mail: \_\_\_\_\_

_____	A	Mounting Bolt Center-to-Center	_____	Idler Length 1
_____	B	Center Roll Height Above Mounting Base	_____	Idler Length 2
_____	C	Inside Structure Dimension	_____	Idler Length 3
_____	D	Trough Angle		
_____	E	Belt Width		
_____	F	Length of Load Zone		
_____	G	Material		
_____	H	Drop Height		
_____	I	Maximum Lump Size		
Length	Width	Height		
_____	J	Tons per Hour		
_____	K	Belt Speed		
_____	W	Maximum Lump Weight		

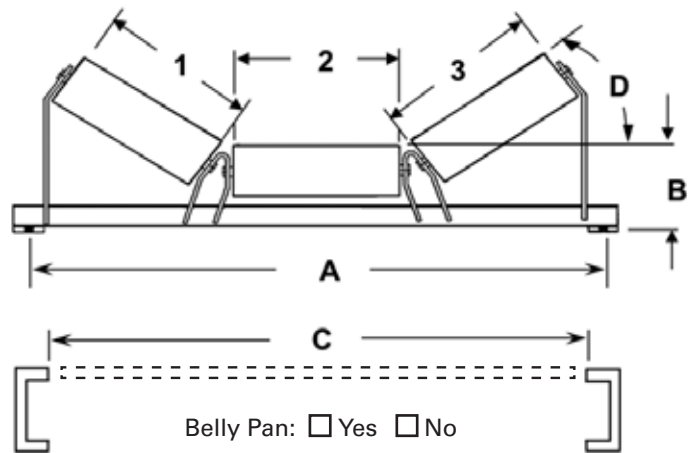

## Impact Energy Calculation Chart

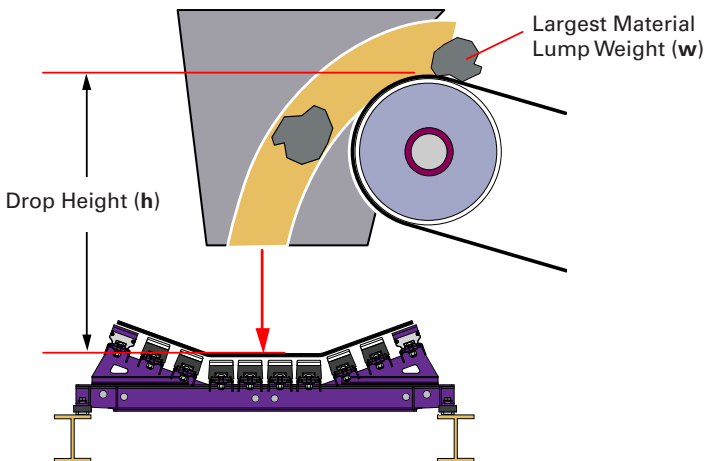

### Impact Energy

Lump Weight (w) \_\_\_\_\_

Drop Height (h) x \_\_\_\_\_

Total - kg-m \_\_\_\_\_

See below for bed recommendation/selection

### Bed Selection:

- Up to 25 kg-m  DRX 200
- 25 to 100 kg-m  DRX 750
- 100 to 200 kg-m  DRX 1500
- 200 to 400 kg-m  DRX 3000

## Section 2 - Safety Considerations and Precautions

---

Before installing and operating the DRX™ Impact Bed, it is important to review and understand the following safety information.

There are set-up, maintenance and operational activities involving both **stationary** and **operating** conveyors. Each case has a safety protocol.

---

### 2.1 Stationary Conveyors

The following activities are performed on stationary conveyors:

- Installation
- Skirt rubber adjustments
- Impact bar replacement
- Cleaning
- Repairs

#### **DANGER**

It is imperative that OSHA/MSHA Lockout/Tagout (LOTO) regulations be followed before undertaking the preceding activities. Failure to use LOTO exposes workers to uncontrolled behavior of the impact bed caused by movement of the conveyor belt. Severe injury or death can result.

Before working:

- Lockout/Tagout the conveyor power source
- Disengage any takeups
- Clear the conveyor belt or clamp securely in place

#### **WARNING**

**Use Personal Protective Equipment (PPE):**

- Safety eyewear
- Hardhats
- Safety footwear

Close quarters and heavy components create a worksite that compromises a worker's eyes, feet and skull.

PPE must be worn to control the foreseeable hazards associated with conveyor belt components. Serious injuries can be avoided.

---

### 2.2 Operating Conveyors

There are two routine tasks that must be performed while the conveyor is running:

- Inspection of the sealing performance
- Dynamic troubleshooting

#### **DANGER**

Every belt conveyor is an in-running nip hazard. Never touch or prod an operating impact bed. Conveyor hazards cause instantaneous amputation and entrapment.

#### **WARNING**

Never adjust anything on an operating impact bed. Unforeseeable materials falling into the chute can cause violent movements of the impact bed structure. Flailing hardware can cause serious injury or death.

#### **WARNING**

Conveyor chutes contain projectile hazards. Stay as far from the impact bed as practical and use safety eyewear and headgear. Missiles can inflict serious injury.



## Section 3 - Pre-Installation Checks and Options

---

### 3.1 Checklist

- Check the model and size of the impact bed. Is it the right one for your beltline?
- Check the bed to be sure all the parts are included in the shipment.
- Find the Information Packet in the shipment.
- Review the “Tools Needed” section on the front of the installation instructions.
- Prepare the conveyor site:
  - Lift the belt in the transfer zone. Use a lifting hoist or Flexco’s Belt Lifters.
  - Remove the old impact bed or impact idlers.
  - Inspect the conveyor structure for damage or misalignment. Make adjustments as necessary.
  - Troughing idlers should be installed directly before and after the new impact bed.

# Section 3 - Pre-Installation Checks and Options

## 3.2 Optional Installation Accessories

Optional tools can make the installation of the DRX™ Impact Bed easier and faster.

### Flex-Lifter Conveyor Belt Lifter

Description	Ordering Number	Item Code
Medium Flex-Lifter™ 900 - 1500mm (36" - 60")	FL-M	76469
Large Flex-Lifter 1200 - 1800mm (48" - 72")	FL-L	76470
XL Flex-Lifter 1800 - 2400mm (72" - 96")	FL-XL	76983

### Flex-Lifter™ Conveyor Belt Lifter

The Flexco Flex-Lifter makes the job of lifting the conveyor belt easy and safe. Using two Flex-Lifters, the belt can be quickly lifted out of the way to install the impact bed. The Flex-Lifter has the highest safe lift rating available at 1800 kg (4000 lbs.) on Medium and Large, and 2725 kg (6000 lbs.) on XL. And it's versatile. It can also be used to lift topside or return side belt for splicing, roller replacement or other maintenance jobs.

Available in three sizes: Medium for belt widths 900 - 1500mm (36" - 60"), Large for belt widths 1200 - 1800mm (48" - 72"), and XL for belt widths 1800 - 2400mm (72" - 96").

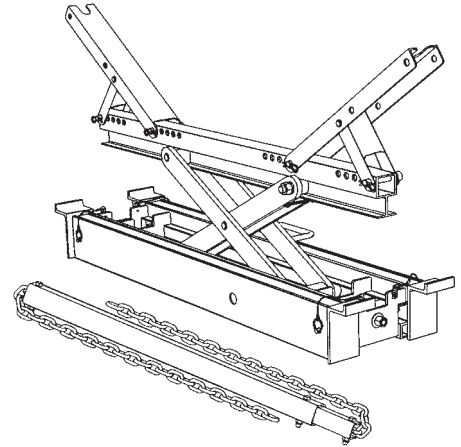

### Impact Bed Shim Kits

Description	Ordering Number	Item Code	Wt. Kg.
DRX200 Shim Kit	SHIM-KITL	77548	6.2
DRX750 Shim Kit	SHIM-KITM	77549	9.3
DRX1500 Shim Kit	SHIM-KITH	77550	12.3

### Shims

Depending on your idler rating and size, shimming may be required. See charts below for quantity of kits required.

### Shim Chart - CEMA C or D Idlers

Impact Bed Size	Cema C or D, 125mm (5") IDLERS	Cema C or D, 150mm (6") IDLERS
DRX200: 600-900mm (24" - 36")	Shim idler up 13mm (1/2")	No Kits Required
DRX200: 1050-1800mm (42" - 72")	No Kits Required	Use (1) SHIM-KITL; Shim up 13mm (1/2")
DRX750: 600-900mm (24" - 36")	Shim idler up 13mm (1/2")	No Kits Required
DRX750: 1050-1800mm (42" - 72")	No Kits Required	Use (1) SHIM-KITM; Shim up 13mm (1/2")
DRX1500: 600-900mm (24" - 36")	Shim idler up 13mm (1/2")	No Kits Required
DRX1500: 1050-1800mm (42" - 72")	No Kits Required	Use (1) SHIM-KITH; Shim up 13mm (1/2")
DRX3000: 1050-1500mm (42"-60)	Shim idler up 50mm (2")	Shim idler up 38mm (1.5")
DRX3000: 1800-2400mm (72"-96")	Shim idler up 64mm (2.5")	Shim idler up 50mm (2")

### Impact Bed Handy Wrench

Description	Ordering Number	Item Code	Wt. Kg.
Impact Bed Handy Wrench	HW-IMPB	76939	0.7



### Impact Bed Handy Wrench

A handy ratcheting wrench with two common sizes (19mm and 24mm or 3/4" and 15/16") for easier installation and maintenance of impact beds.

### Shim Chart - CEMA E Idlers

Impact Bed Size	CEMA E, 150mm (6") IDLERS	CEMA E, 175mm (7") IDLERS
DRX200: 900-1500mm (36"-60")	Use (3) SHIM-KITL; Shim up 38mm (1.5")	Use (4) SHIM-KITL; Shim up 50mm (2")
DRX200: 1800mm (72")	Use (4) SHIM-KITL; Shim up 50mm (2")	Use (5) SHIM-KITL; Shim up 64mm (2.5")
DRX750: 900-1500mm (36"-60")	Use (3) SHIM-KITM; Shim up 38mm (1.5")	Use (4) SHIM-KITM; Shim up 50mm (2")
DRX750: 1800mm (72")	Use (4) SHIM-KITM; Shim up 50mm (2")	Use (5) SHIM-KITM; Shim up 64mm (2.5")
DRX1500: 900-1500mm (36"-60")	Use (3) SHIM-KITH; Shim up 38mm (1.5")	Use (4) SHIM-KITH; Shim up 50mm (2")
DRX1500: 1800mm (72")	Use (4) SHIM-KITH; Shim up 50mm (2")	Use (5) SHIM-KITH; Shim up 64mm (2.5")
DRX3000: 1050-1500mm (42"-60)	No Shim Required	No Shim Required
DRX3000: 1800-2400mm (72"-96")	No Shim Required	No Shim Required

# Section 4 - Installation Instructions

## 4.1 DRX Impact Bed

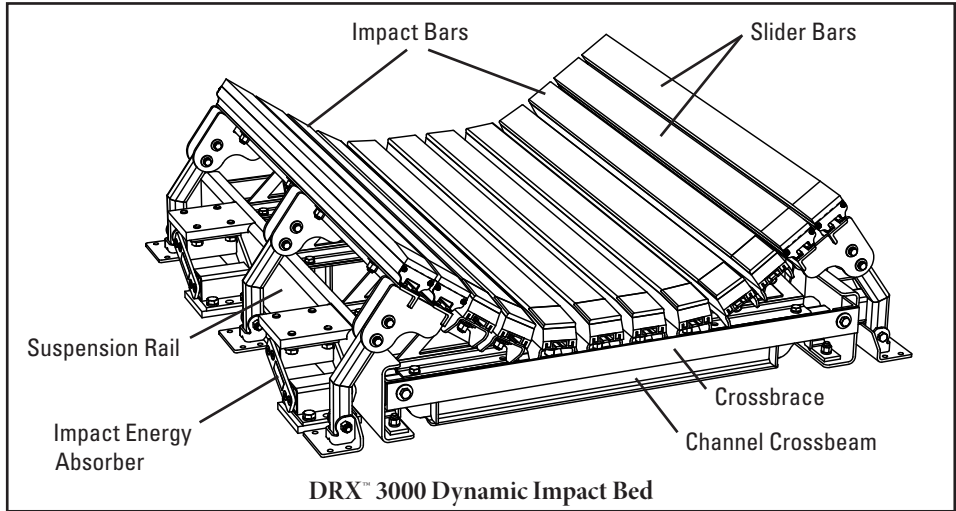

**Physically lock out and tag the conveyor at the power source before you begin cleaner installation.**

**Caution:** Components may be heavy. Use safety approved lifting procedures.

**Before Installation:** Confirm depth of 125mm (5") clearance below the top of the conveyor structure for the impact bed to travel while absorbing the load (Fig. 1). Inspect structure; confirm CEMA rating. Shim bed or idlers per Table 1. **NOTE:** Installation of an idler is required 25-150mm (1-6") before and after a Flexco® DRX™ Impact Bed (Fig. 1a). If more than one impact bed is used, idlers should be installed between every one or two beds.

If CEMA rating is unknown, measure the lead and trail idler for height from top of center roll to the top of conveyor structure. Table 2 shows the nominal center height required for the idler based on belt width. If incorrect, shim idler(s) to the height shown in Table 2.

- Tools Needed:**
- (2) 19 mm (15/16") wrenches or crescent wrenches
  - Measuring Tape
  - (4) C-clamps

**Table 1: Shim Requirements**

Idler Diameter (CEMA C or D)	1050-1500mm (42"- 60") Belt Width	1800-2400mm (72"- 96") Belt Width
125mm (5")	Idler up 50mm (2")	Idler up 64mm (2.5")
150mm (6")	Idler up 38mm (1.5")	Idler up 50mm (2")
Idler Diameter (CEMA E)	42"- 60" (1050-1500mm) Belt Width	72"- 96" (1800-2400mm) Belt Width
150mm (6")	No shim	No shim
175mm (7")	Bed up 13mm (1/2")	Bed up 13mm (1/2")

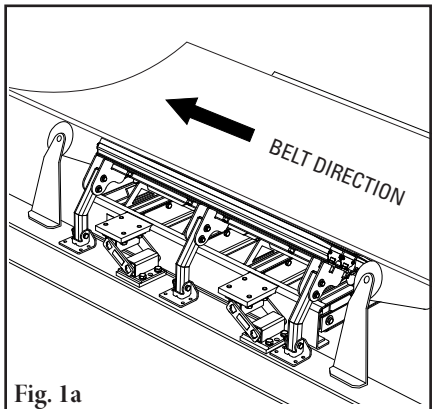
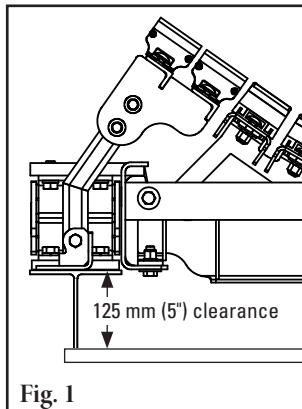

**Table 2: Nominal Center Roll Height**

Belt Width	1050-1500mm (42"- 60")	1800mm (72")	2100-2400mm (84"-96")
Height	273mm (10-3/4")	292mm (11-1/2")	298mm (11-3/4")

## Section 4 - Installation Instructions

### 4.1 DRX Impact Bed (cont.)

1. **Take out the current system.** Remove existing impact idlers or bed from area. Loosen or remove skirting material for extra space. If available, use two Flex-Lifters (before and after the load zone) to lift the belt out of the way.
2. **Visually locate center of loading zone.** Determine the center of the load zone on one side of the structure and mark (Fig. 2). Measure to a fixed point on the structure and then transfer this dimension to the opposite side structure.
3. **Place suspension rails.** Center suspension rails over center marks and clamp lower impact energy absorber to the structure. Impact energy absorber linkages must be positioned to move down and forward in the same direction as belt travel (Fig. 3).

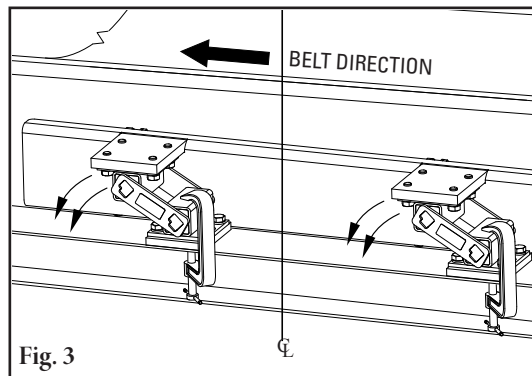
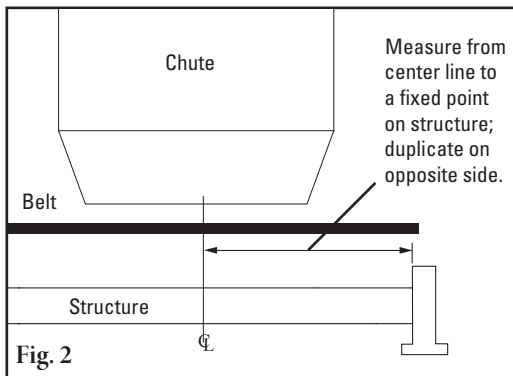

4. **Square suspension rails.** Loosen clamps as necessary. Spread suspension rails until angle of crossbrace fits inside rails and bolt in place. Crossbrace angle should face down and inward (Fig. 4a). Center assembly over the structure. Measure diagonal A-B and C-D dimensions and move until they are equal (Fig. 4b). Tack weld the mounting plates to the structure, then remove impact energy absorbers mounting bolts, slide center assembly off the mounting plates, and finish welding mounting plates to structure (Fig. 4c). Slide center assembly back onto mounting plates and reinstall bolts.

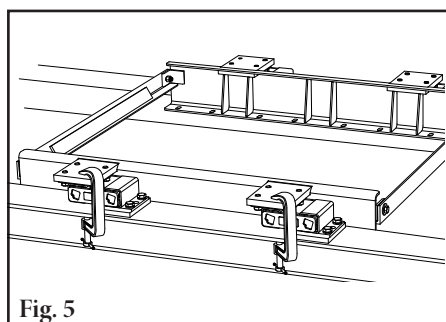
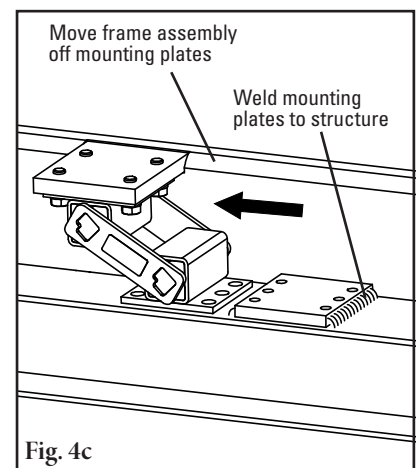
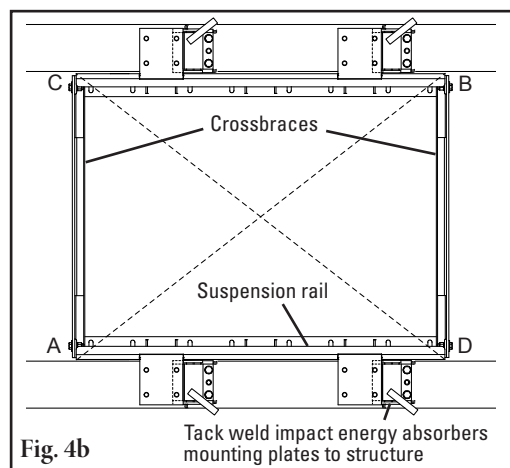
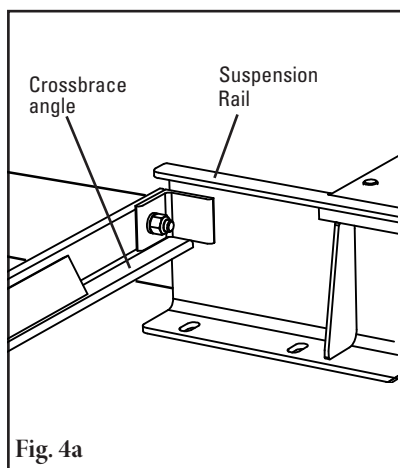

5. **Compress suspension rails.** Compress suspension rails with four C-clamps to give an additional 63mm (2.5") of clearance for assembly (Fig. 5).

# Section 4 - Installation Instructions

## 4.1 DRX Impact Bed (cont.)

6. **Disassemble wing assemblies.** Remove the center mount bolt and the two outer flange bolts. Slide out and remove the wing assembly on each channel crossbeam (Fig. 6). (Keep bolts, nuts and washers for use later.)

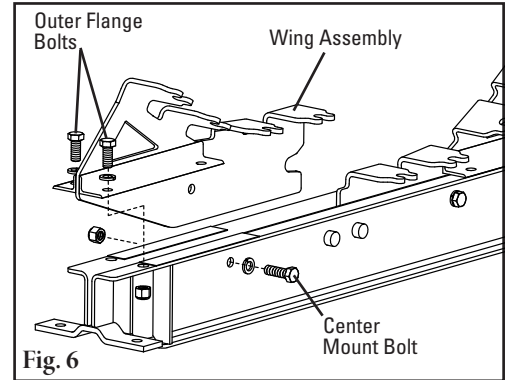

7. **Install crossbeams.** Slide all crossbeams between belt and suspension rail and set on lower inside flange of suspension rail. Bolt in place with bolts facing up to minimize space constraints (Fig. 7).

**NOTE:** Crossbeams must all be in line before tightening down.

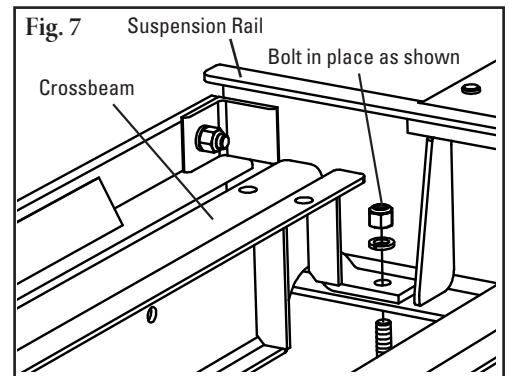

8. **Install wings into the crossbeams.** Lift and slide wing plates in until the outer mounting holes of the wing bracket align with the inner mounting holes of the crossbeam (Fig. 8a). Reinsert the two mounting bolts and the center retaining bolt in each wing bracket (Fig. 8b). Tighten to 135 N-m (100 ft-lb.).

**NOTE:** Confirm all of the bar mounting tabs on the wings are pointing towards the tail pulley.

9. **Install impact bars.** Place all the impact bars in place. Position studs between the tabs in the wing bracket; confirm the chamfer of the impact bar is positioned at the tail pulley end of the bed (Fig. 9).

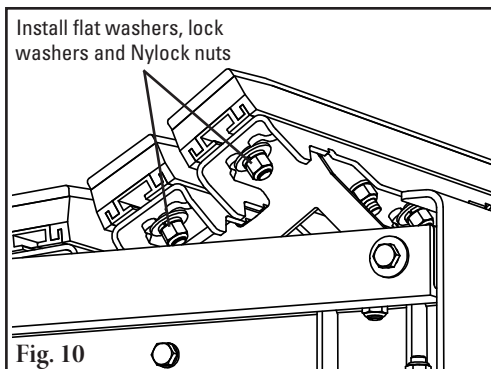
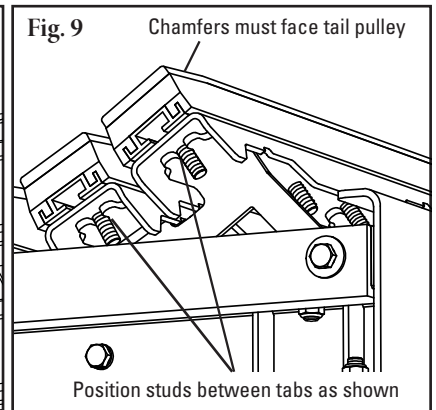
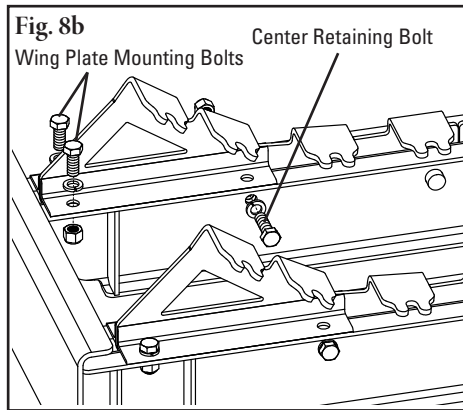
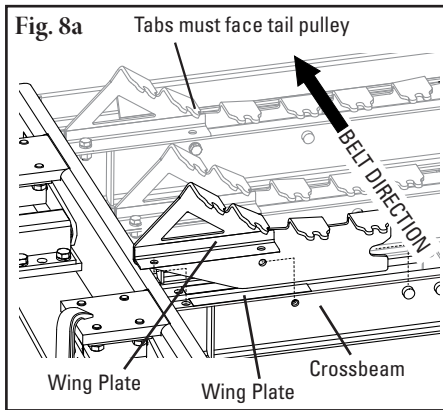

10. **Fasten impact bars.** With all the impact bars correctly positioned on the wing brackets, install a flat washer, lock washer and nylock nut on each stud. Tighten nuts to 135 N-m (100 ft-lb.) torque (Fig. 10). Remove C-clamps from impact energy absorbers.

## Section 4 - Installation Instructions

### 4.1 DRX Impact Bed (cont.)

11. **Install stationary arms.** Place stationary arms onto structure, aligning holes in bases with center holes of impact energy absorbers (Fig. 11a). (Chamfer on stationary bars must face tail pulley.) Align ends of stationary impact bars flush with center bars (Fig. 11b). Clamp in place and tack weld stationary arms to structure on both sides.

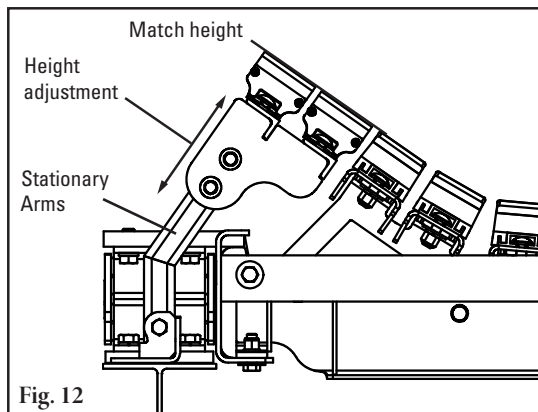
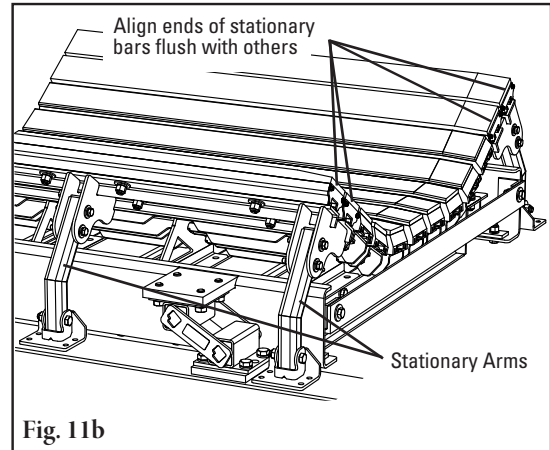
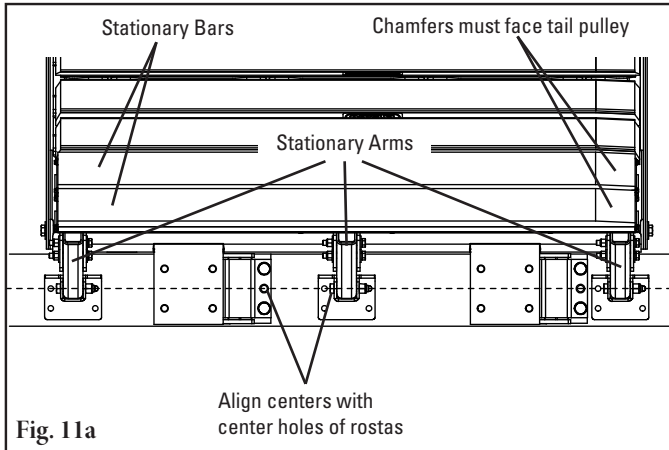

12. **Adjust stationary arms.** Loosen upper bolts on stationary arms and adjust height to match belt and chute. Retighten bolts. Finish welding arms in place onto the structure (Fig 12).

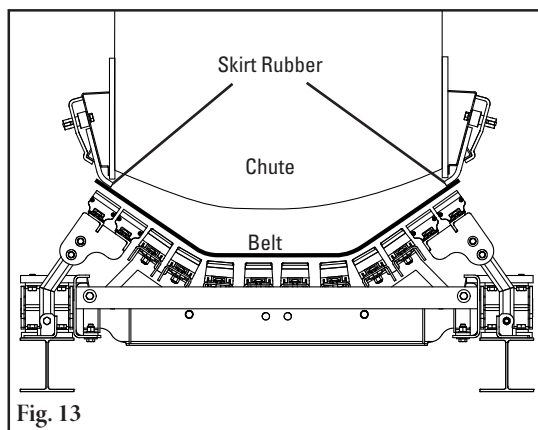

13. **Confirm correct clearance between chute and belt.** Readjust skirt rubber to make a good seal against impact bed (Fig 13). Replace all protective guarding around load zone.

## Section 5 - Pre-Operation Checklist and Testing

---

### 5.1 Pre-Op Checklist

- Recheck that all fasteners are tight
- Check that empty belt is 13mm (1/2") above the impact bars
- Apply all supplied labels
- Be sure that all installation materials and tools have been removed from the belt and conveyor area

### 5.2 Test Run the Conveyor

- Run the conveyor for at least 15 minutes and confirm the skirt rubber is properly sealing the transfer point. Adjust skirt rubber as needed.

## Section 6 - Maintenance

---

Flexco impact beds are designed to operate with minimum maintenance. However, to maintain superior performance some service is required. When the impact bed is installed a regular maintenance program should be set up. This program will ensure that the impact bed operates at optimal efficiency, and problems can be identified and fixed before any damage is done to the belt, the bed, other conveyor components, or structure.

All safety procedures for inspection of equipment (stationary or operating) must be observed. The DRX Impact Bed operates in the loading zone of the conveyor system and is in direct contact with the moving belt. Only visual observations can be made while the belt is running. Service tasks can be done only with the conveyor stopped and by observing the correct lockout/tagout procedures.

### 6.1 New Installation Inspection

After the impact bed has run for a few days a visual inspection should be made to ensure the bed is performing properly. Make adjustments as needed.

### 6.2 Routine Visual Inspection (every 2-4 weeks)

A visual inspection of the impact bed can determine:

- If the skirt rubber is adequately keeping the chute area sealed
- If the impact bars are worn out and need to be replaced
- If there are excessive materials building up around the impact bed
- If there is damage to the impact bed, belt or other conveyor components

If any of the above conditions exist, a determination should be made on when the conveyor can be stopped for cleaner maintenance.

### 6.3 Routine Physical Inspection (every 6-8 weeks)

When the conveyor is not in operation and properly locked and tagged out, a physical inspection of the cleaner to perform the following tasks:

- Clean material buildup off the impact bed and conveyor structure.
- Closely inspect each impact bar for wear and damage. Replace if needed.
- Check the impact bed frame for damage.
- Inspect all fasteners for tightness and wear. Tighten or replace as needed.
- Inspect skirt rubber and adjust as needed to compensate for impact bar wear.
- When maintenance tasks are completed, test run the conveyor to ensure the impact bed is performing properly.



# Section 6 - Maintenance

## 6.4 Impact Bar Replacement Instructions

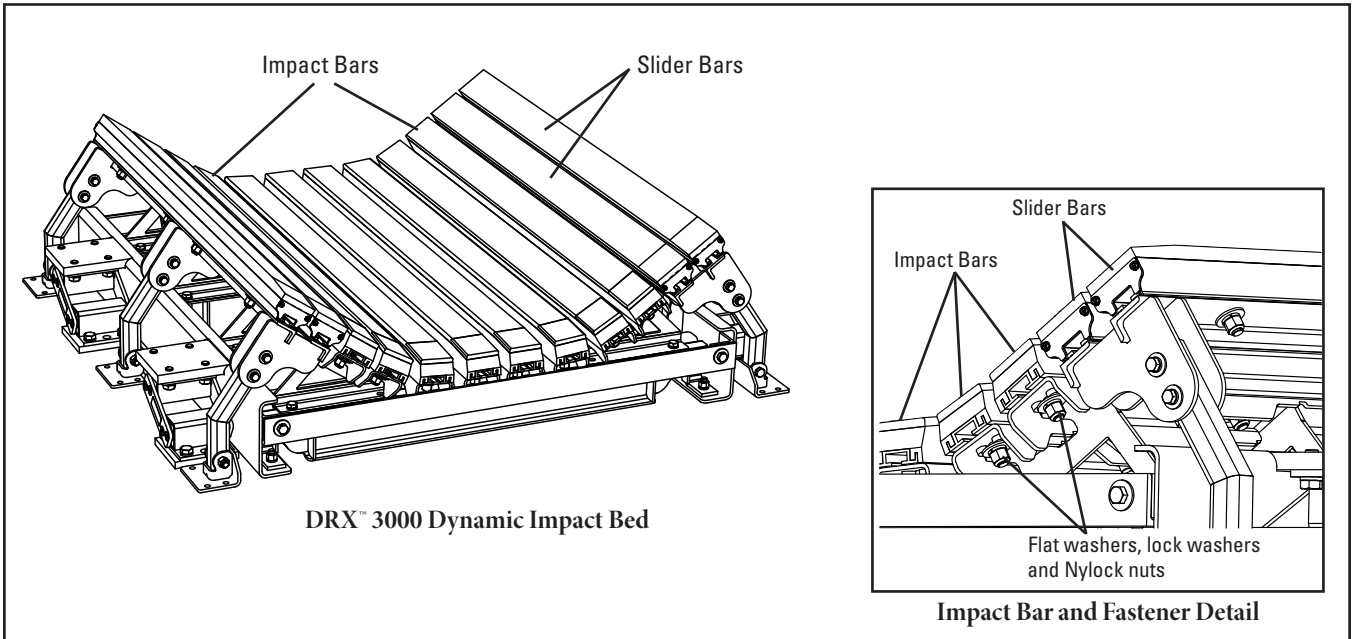

**Physically lock out and tag the conveyor at the power source before you begin cleaner installation.**

- Tools Needed:**
- (2) 24 mm (15/16") wrenches or crescent wrenches
  - Broom, wire brush and/or putty knife (for cleaning bed and structure)
  - Come-along
  - (4) C-clamps

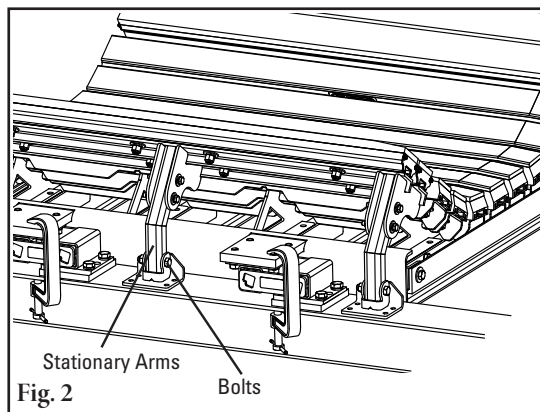
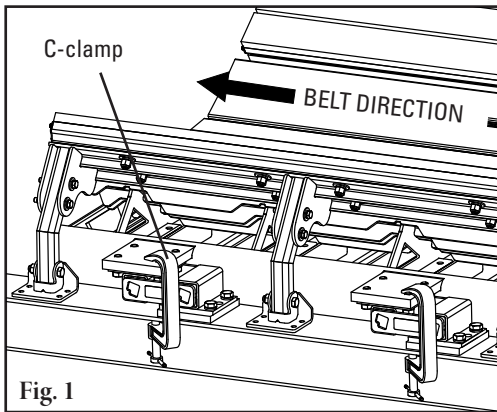

1. **Remove tension.** Use a Flexco® Belt Lifter or other appropriate lifting equipment to lift the belt off the impact bed. Compress impact energy absorbers with C-clamp (Fig. 1).
2. **Remove stationary bars.** Remove bolts at bases of stationary arms and lift assembly out of the way (Fig. 2).

## Section 6 - Maintenance

### 6.4 Impact Bar Replacement Instructions (cont.)

- 3. Inspect bars.** Check to see which bars are worn or damaged and need to be replaced.
- 4. Remove worn bars.** Loosen and remove nuts at each cross stringer and remove the impact bar and bar support (Fig. 4).

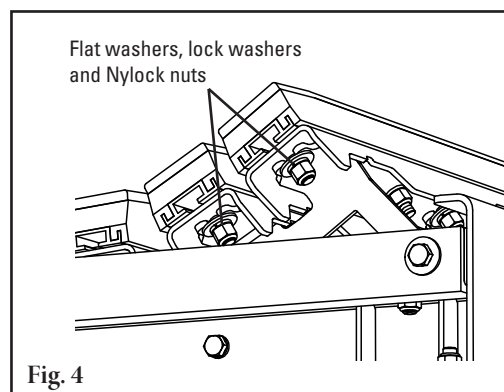

- 5. Remove support bar.** Remove the nuts holding the support in place and attach to the new impact bar (Fig. 5).

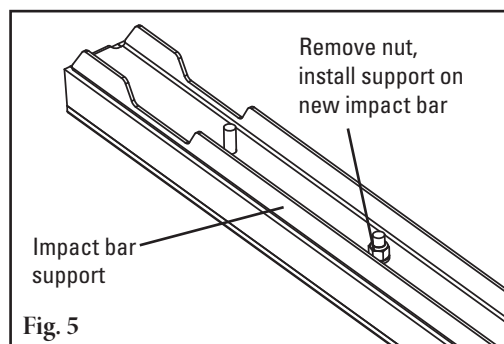

- 6. Install new bar and support onto the bed.** Place the new impact bar and bar support onto the bed with the chamfered end facing the tail pulley (Fig. 6). Line up the bolts and tighten the bars to the cross stringers.

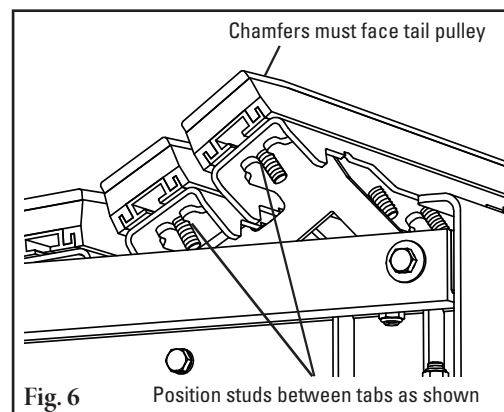

- 7. Remove C-clamps from impact energy absorbers and adjust and tighten all bolts (Fig. 7).**

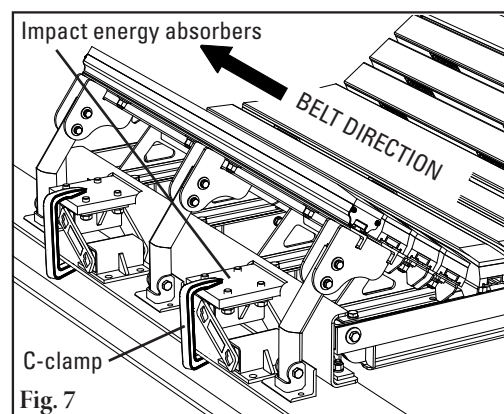

## Section 6 - Maintenance

### 6.4 Impact Bar Replacement Instructions (cont.)

8. **Replace stationary bar(s).** Replace bar(s) on stationary arm assembly if needed, and reinstall arms into mounting bases. Insert and tighten bolts (Fig. 8).

**Test run the conveyor.** Run the conveyor for a few minutes and inspect to ensure that the bed is performing properly. Make adjustments as necessary.

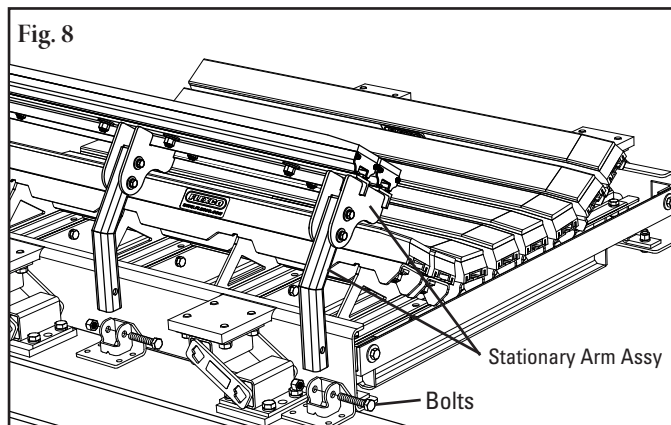

## Section 6 - Maintenance

---

### 6.5 Maintenance Log

Conveyor Name/No. \_\_\_\_\_

Date: \_\_\_\_\_ Work done by: \_\_\_\_\_ Service Quote #: \_\_\_\_\_

Activity: \_\_\_\_\_

---

Date: \_\_\_\_\_ Work done by: \_\_\_\_\_ Service Quote #: \_\_\_\_\_

Activity: \_\_\_\_\_

---

Date: \_\_\_\_\_ Work done by: \_\_\_\_\_ Service Quote #: \_\_\_\_\_

Activity: \_\_\_\_\_

---

Date: \_\_\_\_\_ Work done by: \_\_\_\_\_ Service Quote #: \_\_\_\_\_

Activity: \_\_\_\_\_

---

Date: \_\_\_\_\_ Work done by: \_\_\_\_\_ Service Quote #: \_\_\_\_\_

Activity: \_\_\_\_\_

---

Date: \_\_\_\_\_ Work done by: \_\_\_\_\_ Service Quote #: \_\_\_\_\_

Activity: \_\_\_\_\_

---

Date: \_\_\_\_\_ Work done by: \_\_\_\_\_ Service Quote #: \_\_\_\_\_

Activity: \_\_\_\_\_

---

Date: \_\_\_\_\_ Work done by: \_\_\_\_\_ Service Quote #: \_\_\_\_\_

Activity: \_\_\_\_\_

---



## Section 7 - Troubleshooting

---

Problem	Possible Cause	Possible Solutions
Bars wearing out too fast	Impact bars are not at 13mm below leading and trailing idlers	Adjust/shim as needed to correct dimension
	More than two beds in a row without idler between	Add an idler between at least every other bed to lift the belt back up
	Leading idler does not match troughing angle	Correct the angle of the leading idler to match the bed
Vibration or noise	Belt rubbing too hard on UHMW impact bar covers	Verify height of leading/trailing idlers
	Material buildup under bed	Clean up buildup
	Skirt rubber pushing too hard on belt	Adjust skirt rubber
Bars deforming	Larger material than specified is flowing through transition (under-specified bed)	Replace with a heavier-duty version of impact bed or add additional bar supports
Bar damage	Mechanical splice damaging UHMW top covers	Repair, skive or replace splice

For more information on selection and proper usage of impact beds, ask Flexco Customer Service for one or more of the following DRX™ Tech Tips:

- X1945 - DRX Tech-Tip #1      Spec'ing and recommending DRX Impact Beds
- X1946 - DRX Tech-Tip #2      Impact beds vs. slider beds with rollers - Is it just a matter of choice?
- X1947 - DRX Tech-Tip #3      Over-specifying an impact bed isn't a good idea

# Section 8 - Specs and CAD Drawings

## 8.1 Specifications and Guidelines

**Bed Length:** 1.5M

**Troughing Angles:** 20° and 35°

**Bed Specs per lump size and drop height needs:**

(Per Conveyor Equipment Manufacturers Association (CEMA) guidelines)

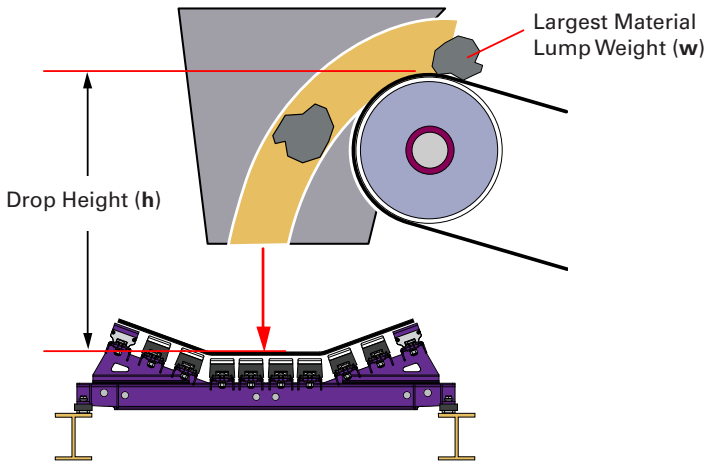

**Impact Energy Calculation:**

Lump weight \_\_\_\_\_ kg  
 x Drop length \_\_\_\_\_ m  
 -----  
 Total \_\_\_\_\_ kg-m

**Bed Rating:**

200 to 400 kg-m ..... DRX3000

**Slider Bars and Impact Bars per Belt Width (DRX 3000)**

Belt Width - mm	1050	1200	1350	1500	1800	2100	2400
Belt Width - in.	42	48	54	60	72	84	96
<b>SLIDER BARS</b>							
DRX3000	2	2	4	4	4	4	4
<b>IMPACT BARS</b>							
DRX3000	8	8	8	9	12	12	16

**Impact Bar Supports and Bolt Kits per Belt Width**

Belt Width - mm	1050	1200	1350	1500	1800	2100	2400
Belt Width - in.	42	48	54	60	72	84	96
<b>BAR SUPPORTS</b>							
DRX3000	8	8	8	9	12	12	16
<b>BOLT KITS</b>							
DRX3000	56	56	64	70	88	88	112

# Section 8 - Specifications and CAD Drawings

## 8.2 CAD Drawing - DRX3000 - 1.5M Bed Length

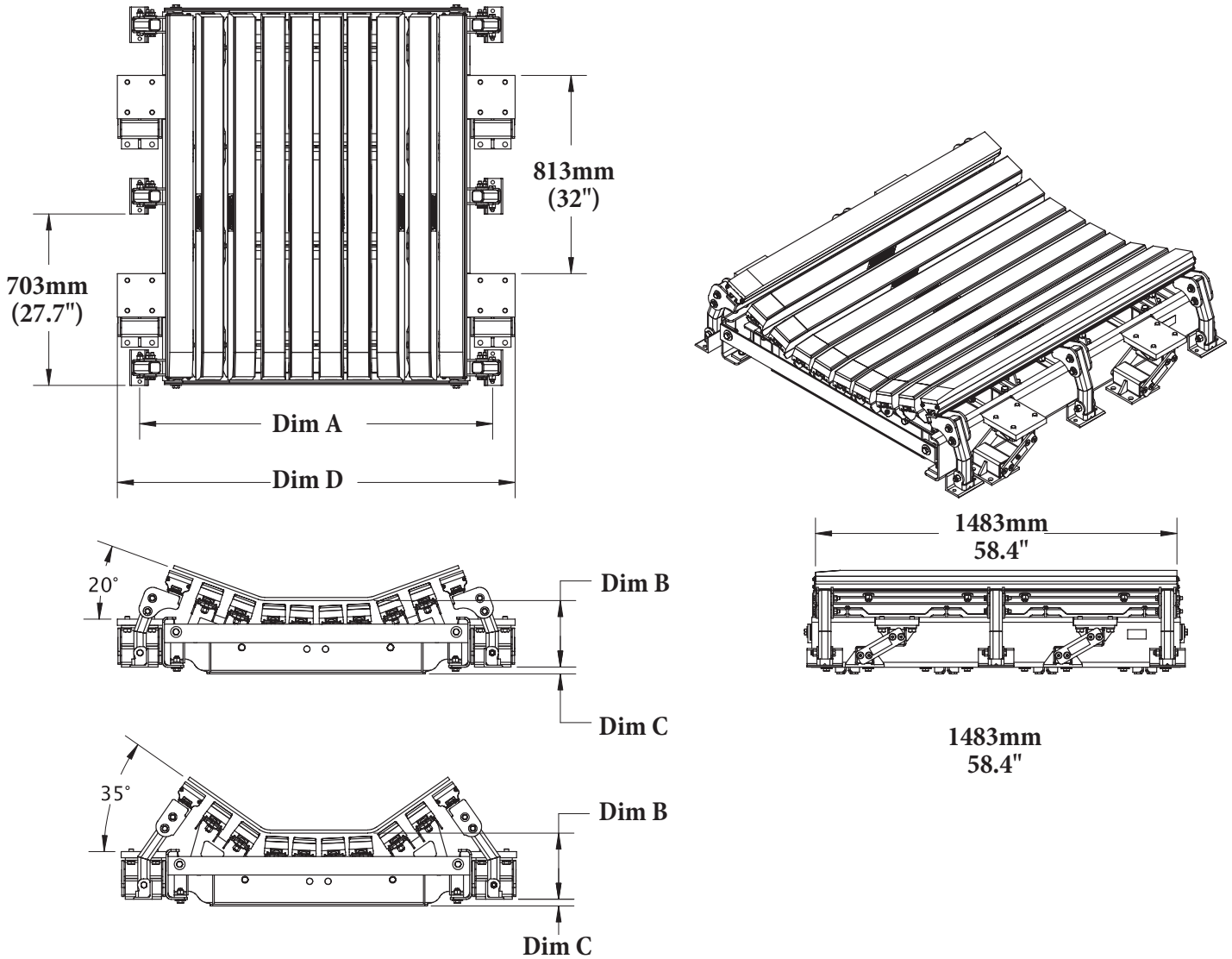

Bed Width	Dim A	Dim B	Dim C	Dim D
1050mm (42")	1295.4mm (51")	273mm (10.75")	27.7mm (1.09")	1479.6mm (58.25")
1200mm (48")	1447.8mm (57")	273mm (10.75")	27.7mm (1.09")	1632.0mm (64.25")
1350mm (54")	1600.2mm (63")	273mm (10.75")	27.7mm (1.09")	1784.4mm (70.25")
1500mm (60")	1752.6mm (69")	273mm (10.75")	27.7mm (1.09")	1936.8mm (76.25")
1800mm (72")	2057.4mm (81")	292.1mm (11.75")	29.1mm (1.15")	2292.4mm (90.25")
2100mm (84")	2362.2mm (93")	292.1mm (11.75")	29.1mm (1.15")	2597.2mm (102.25")
2400mm (96")	2667.0mm (105")	292.1mm (11.75")	29.1mm (1.15")	2902.0mm (114.25")



# Section 9 - Replacement Parts

## 9.1 Optional Replacement Parts

### Replacement Parts

Ref	Description	Ordering Number	Item Code	Wt. Kg.
1	Impact Bar, 1.5 m (13 mm UHMW)	IB5	76927	9.6
2	Impact Bar Bolt Kit incl. (1) ea 16 mm carriage bolt, square washer, flat washer, lock washer, Nylock nut	IBBK	76928	0.2
3	Impact Bar Support - DH 1.5 M incl. (1) bar support, (2) ea carriage bolt, square washer, lock washer, Nylock nut	IBS-DH5	76934	9.5
4	Sliding Support Arm Bolt Kit incl. (4) 38 mm bolts, (2) 50 mm bolts, (6) lock washers, (6) Nylock nuts	ISABK	76935	0.9
5	Impact Energy Absorber 1050 - 1500mm	IEA-42-60	76937	19.1
6	Impact Energy Absorber 1800 - 2400mm	IEA-72-96	76938	30.0

Lead time: 1 working day

### Optional Impact Bar Bolt Kit

13mm carriage bolt, square washer, flat washer and Nylock nut to mount DRX™ Impact Bars on other OEM beds that use 13mm T-bolts.

#### Impact Bar Bolt Kit for Other OEM Impact Beds\*

Description	Ordering Number	Item Code	Wt. Kg.
Optional Impact Bar Bolt Kit	OIBBK	76950	0.2

\*Kit includes 1 ea. bolt, square washer, flat washer and nut.

Lead time: 1 working day

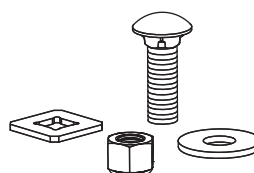

Optional Impact Bar Bolt Kit

### Slider Bars and Impact Bars per Belt Width (DRX 3000)

Belt Width - mm	1050	1200	1350	1500	1800	2100	2400
Belt Width - in.	42	48	54	60	72	84	96
<b>SLIDER BARS</b>							
DRX3000	2	2	4	4	4	4	4
<b>IMPACT BARS</b>							
DRX3000	8	8	8	9	12	12	16

### Impact Bar Supports and Bolt Kits per Belt Width

Belt Width - mm	1050	1200	1350	1500	1800	2100	2400
Belt Width - in.	42	48	54	60	72	84	96
<b>BAR SUPPORTS</b>							
DRX3000	8	8	8	9	12	12	16
<b>BOLT KITS</b>							
DRX3000	56	56	64	70	88	88	112

### Impact Bed Handy Wrench

A ratcheting wrench with 2 common socket sizes 19mm & 24mm for installation and maintenance of impact beds.

#### Impact Bed Handy Wrench

Description	Ordering Number	Item Code	Wt. Kg.
Impact Bed Handy Wrench	HW-IMPB	76939	0.7

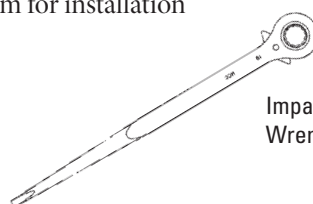

Impact Bed Handy Wrench



## Section 10 – Other Flexco Conveyor Products

---

Flexco provides many conveyor products that help your conveyors to run more efficiently and safely. These components solve typical conveyor problems and improve productivity. Here is a quick overview on just a few of them:

### EZP1 Precleaner



- Patented ConShear™ blade renews its cleaning edge as it wears
- Visual Tension Check™ for optimal blade tensioning and simple retensioning
- Quick and easy one-pin blade replacement Material Path Option™ for optimal cleaning and reduced maintenance

### Flex-Lok™ Skirt Clamps

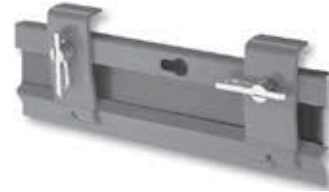

- Eliminates transfer zone spillage
- Interlocking design for easy installation and one person maintenance
- Unique wedge pin holds rubber securely in place and is easy to adjust
- Available in various models and in stainless steel

### EZS2 Secondary Cleaner



- Long-wearing tungsten carbide blades for superior cleaning efficiency
- Patented FormFlex™ cushions independently tension each blade to the belt for consistent, constant cleaning power
- Easy to install, simple to service
- Works with Flexco mechanical belt splices

### PT Max™ Belt Trainer



- Patented “pivot & tilt” design for superior training action
- Dual sensor rollers on each side to minimize belt damage
- Pivot point guaranteed not to seize or freeze up
- Available for topside and return side belts

### Flexco Specialty Belt Cleaners



- “Limited space” cleaners for tight conveyor applications
- High Temp cleaners for severe, high heat applications
- A rubber fingered cleaner for chevron and raised rib belts
- Multiple cleaner styles in stainless steel for corrosive applications

### Belt Plows



- A belt cleaner for the tail pulley
- Exclusive blade design quickly spirals debris off the belt
- Economical and easy to service
- Available in vee or diagonal models

## **The Flexco Vision**

To become the leader in maximising  
belt conveyor productivity for our customers worldwide  
through superior service and innovation.

